

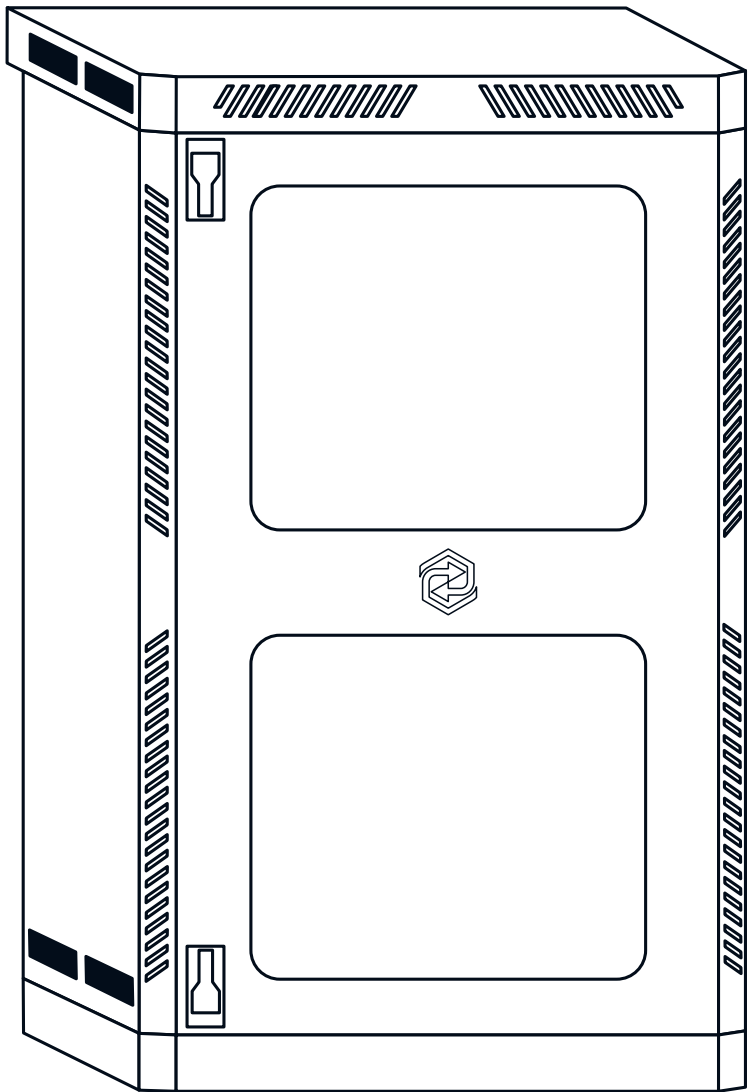

5 WAY BATTERY CABINET

5 WAY INDOOR BATTERY CABINET BUILD INSTRUCTION MANUAL



www.sunsynkmobile.com / sales@sunsynkmobile.com



SPECIFICATION:

Product Description	SM05WAYBC
Dimensions & Features	
Packaging	Flat Pack 2 Box's
Box 1 of 2 Net Weight (kg)	30.7
Box 1 of 2 Gross Weight (kg)	36.4
Box 1 of 2 Size (H x W x D mm)	235 x 950 x 605
Box 2 of 2 Net Weight (kg)	29.3
Box 2 of 2 Gross Weight (kg)	33
Box 2 of 2 Size (H x W x D mm)	200 x 905 x 835
Cabinet Assembled Size (H x W x D mm)	1005 x 585 x 920
Material	1.2mm Mild Steel
Finish	Powder Coated Black
Locking Mechanism	Lockable Lift & Turn Compression Latch
Capacity	Sunsynk 5 x 5kWh Battery or 4 x 5kWh Battery Plus Rack Mount Inverter
Gland Knockout Holes	Right x 4, Left x 4, Rear x 8
Gland Knockout Holes Diameter	Right=2 x 25mm + 2 x 32mm, Left=2 x 25mm + 2 x 32mm, Rear=4 x 25mm + 4 x 32mm
Feet	Adjustable Thread 0 - 25mm
Ventilation	Duel Fan with Bimetal Thermostat & Mains Plug Socket
Temperature Control	Adjustable Bimetal Thermostat (Preset 25°C)
Plug Type (Supplied)	UK/SA/EU (Model Dependent)
Electrical Data	
Max. Current (A)	0.26
Nominal Input/Output Voltage (Vac)	220-240
Nominal Input/Output Frequency (Hz)	50/60
IP Rating	
IP	IP20

PLEASE NOTE

For set up of the inverter and batteries, please refer to the manufacturers manual.

PARTS:

a Base

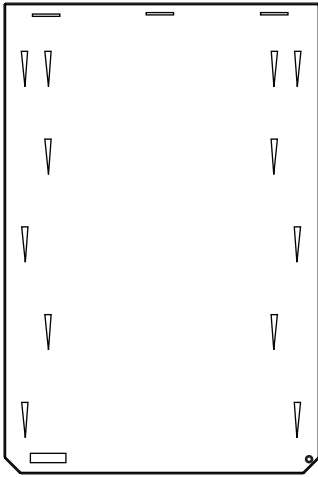

b Right Hand Side

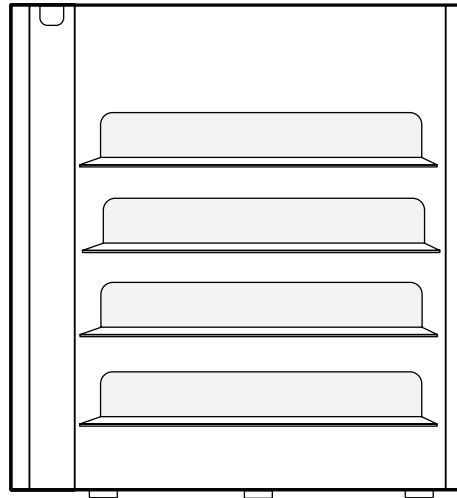

c Left Hand Side

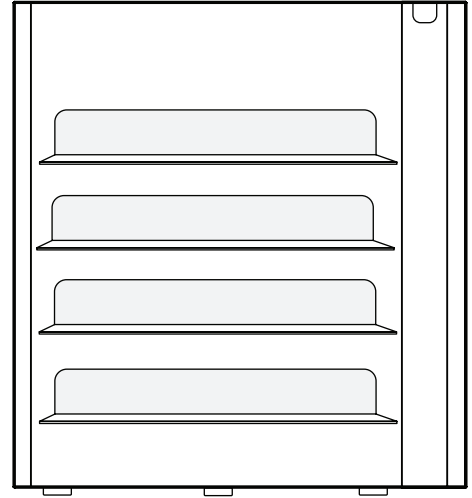

d Back Panel

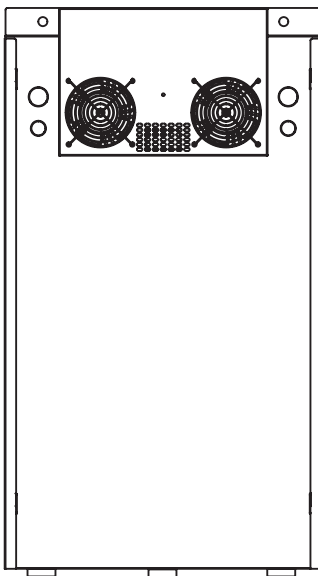

e Top Panel



f Door

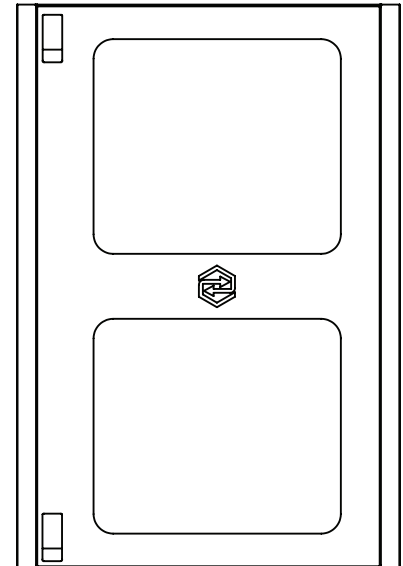

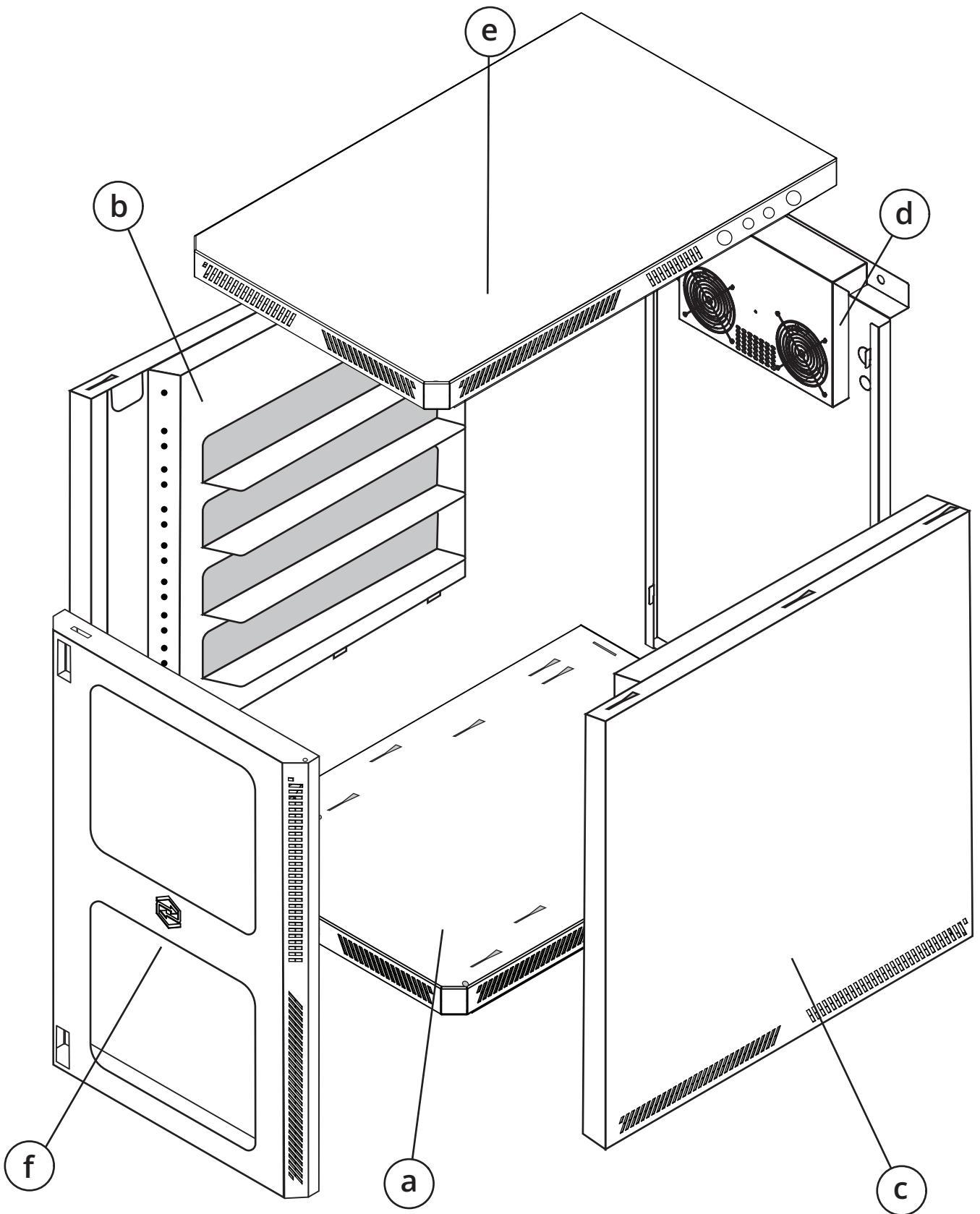

1

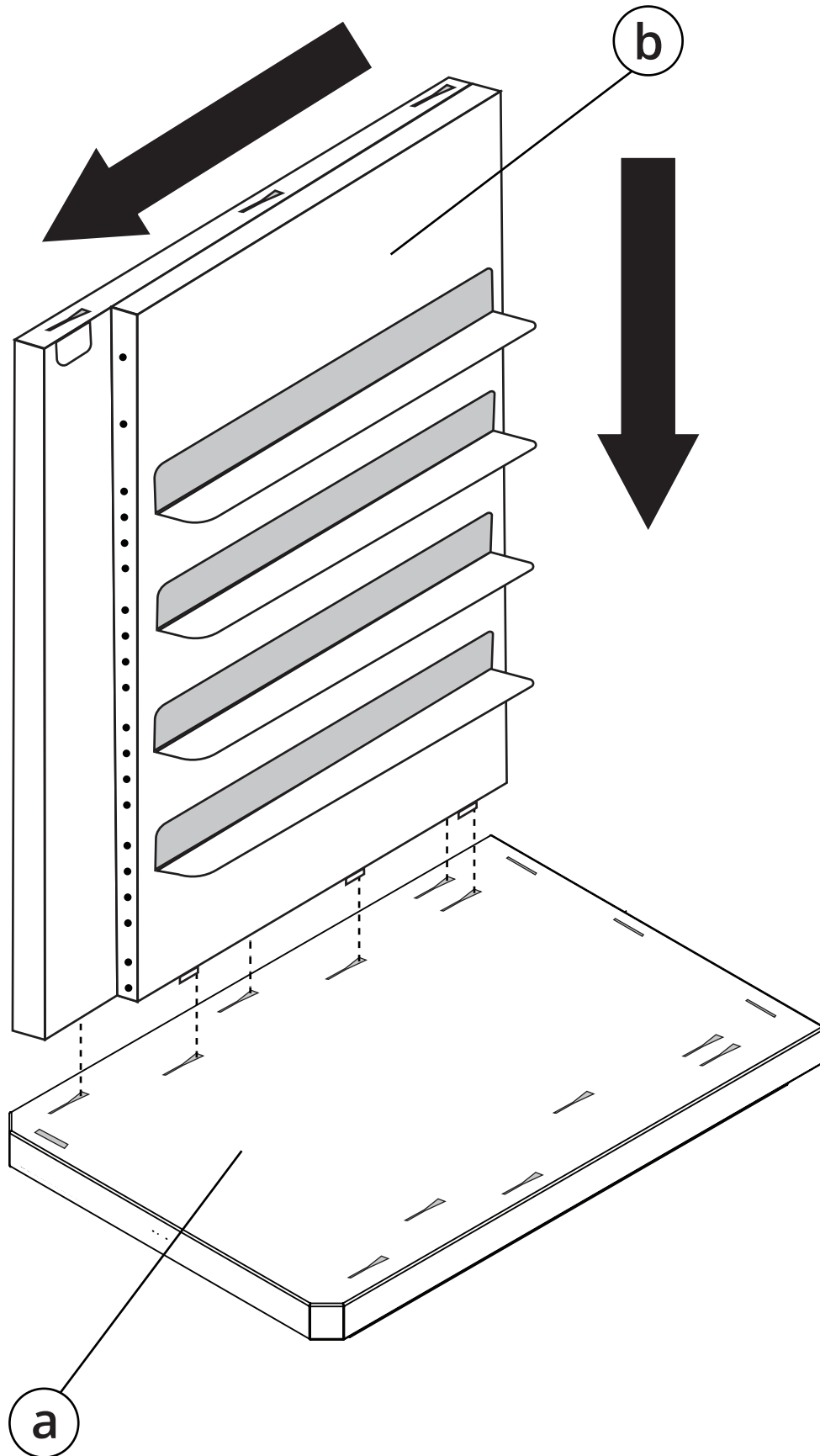

2

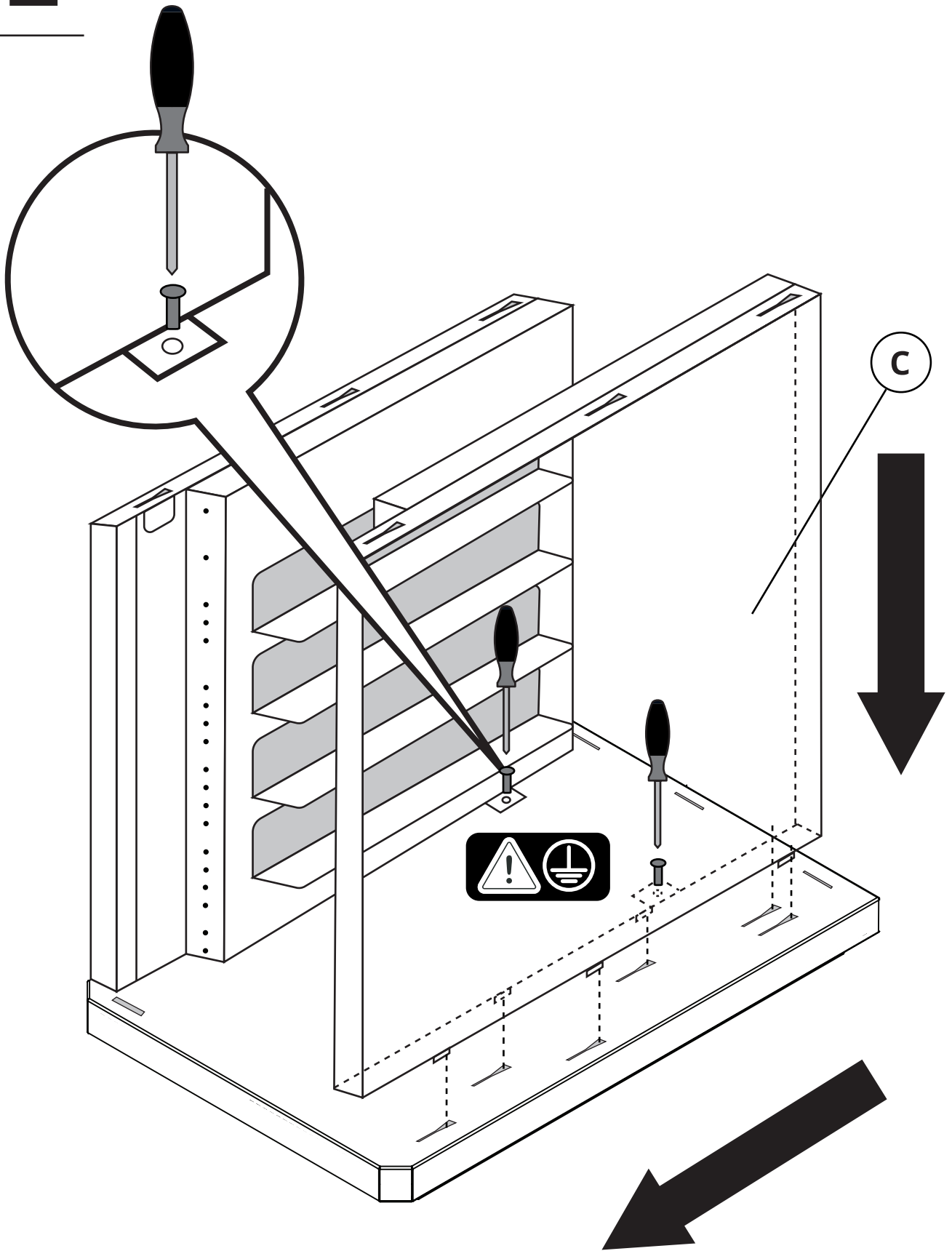

3

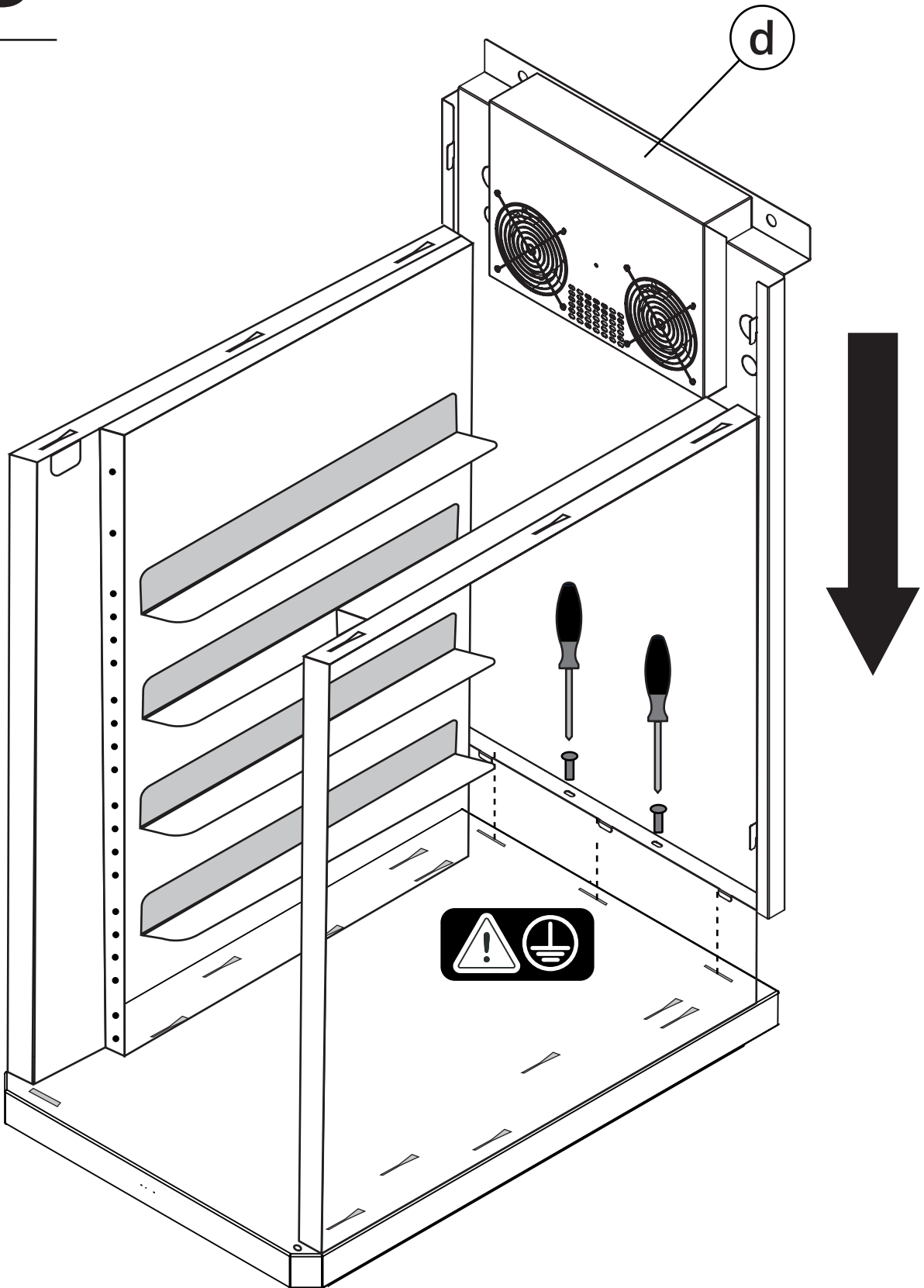

4

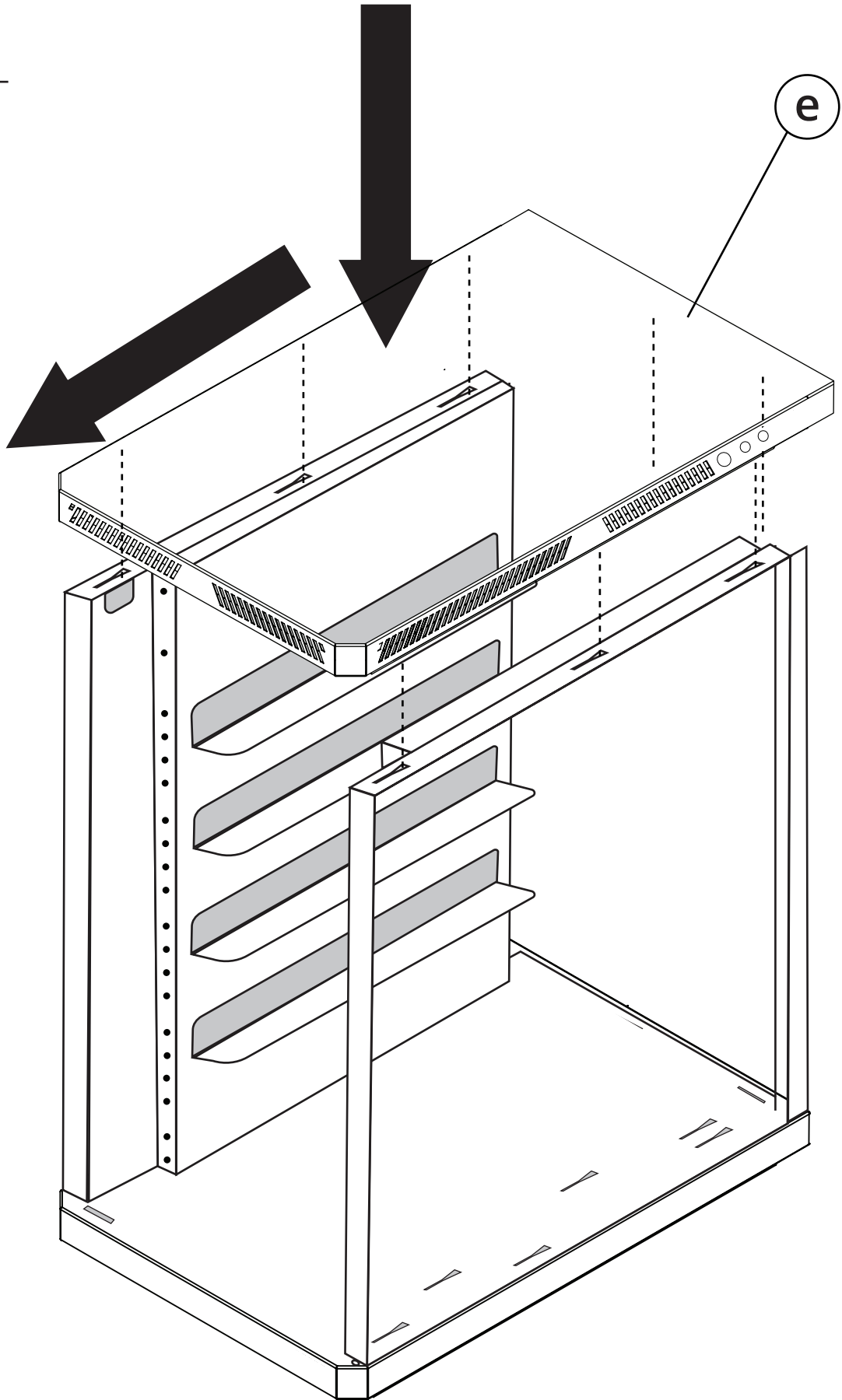

5

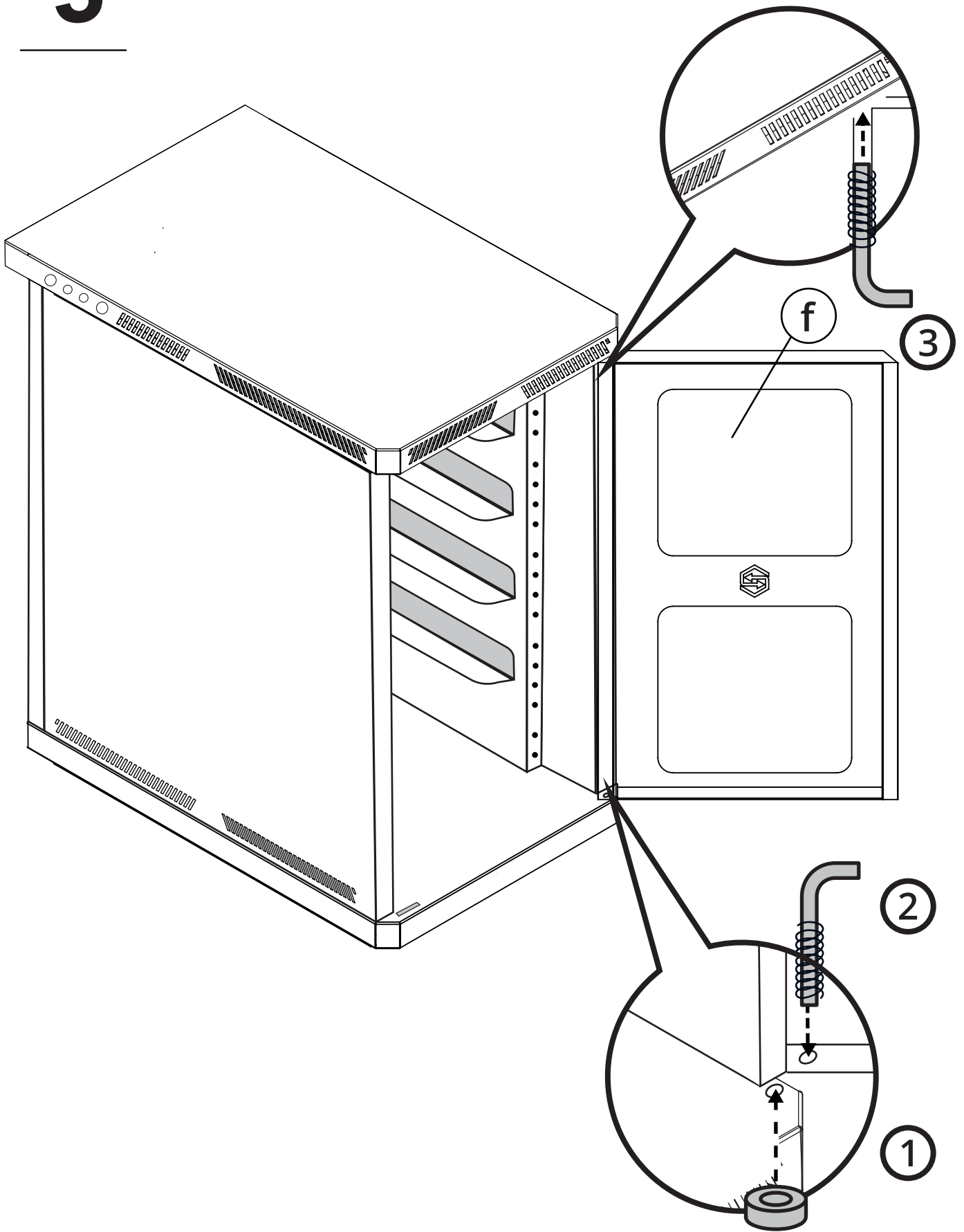

6

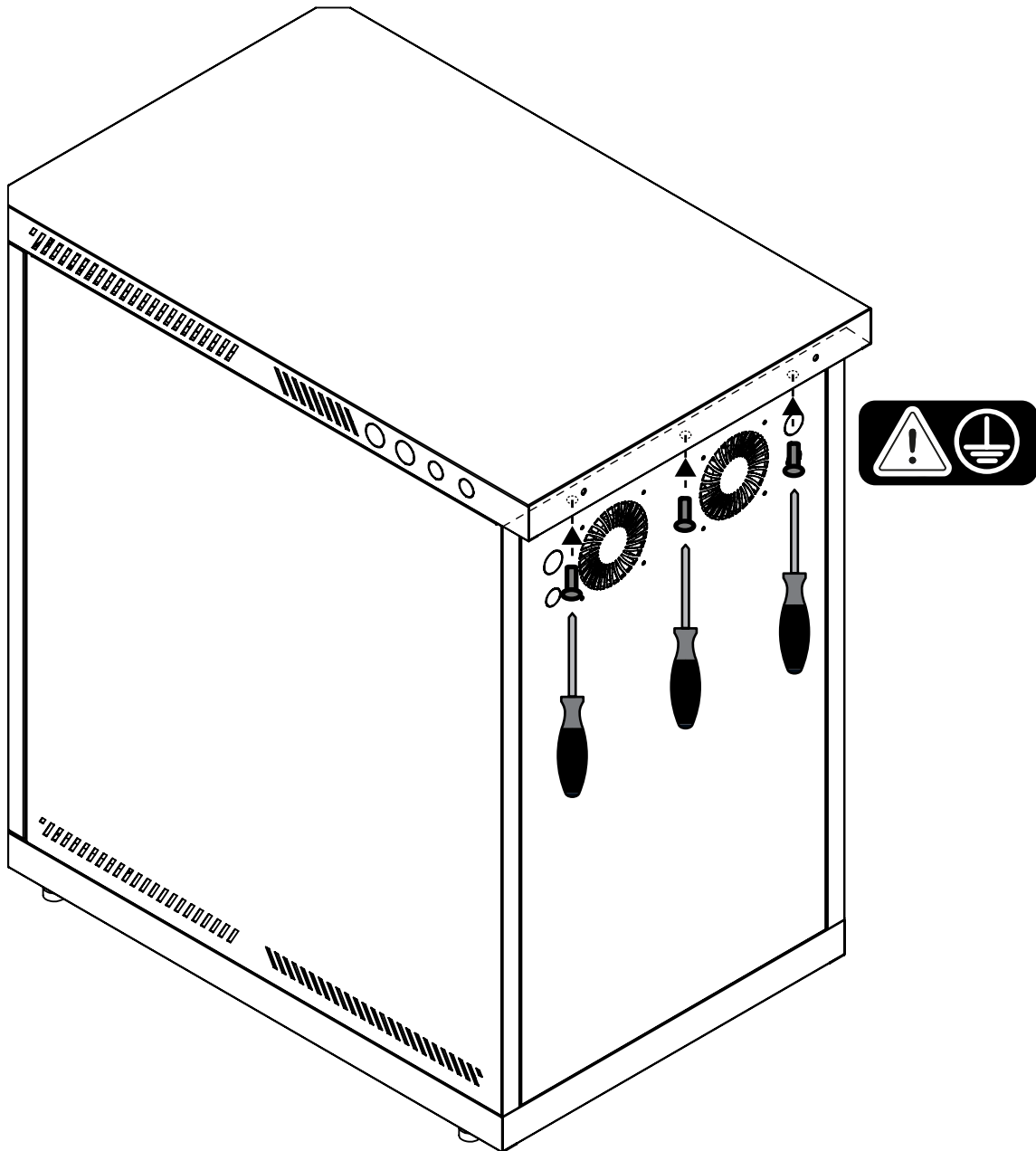

EARTHING:

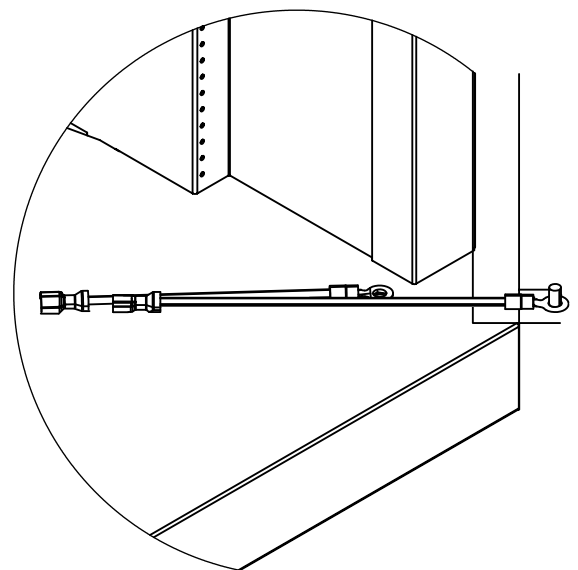
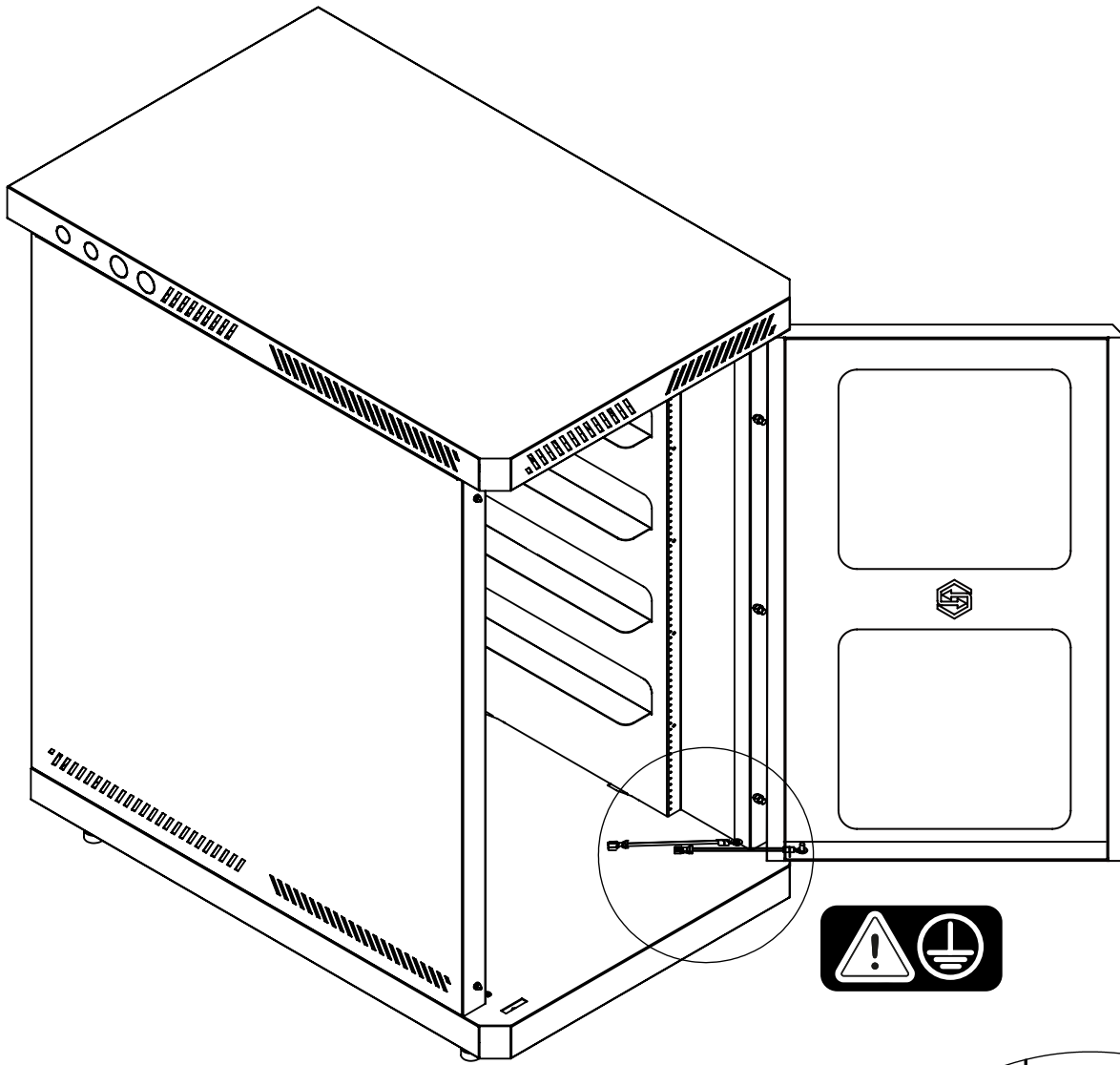

CONNECTING THE COOLING SYSTEM:

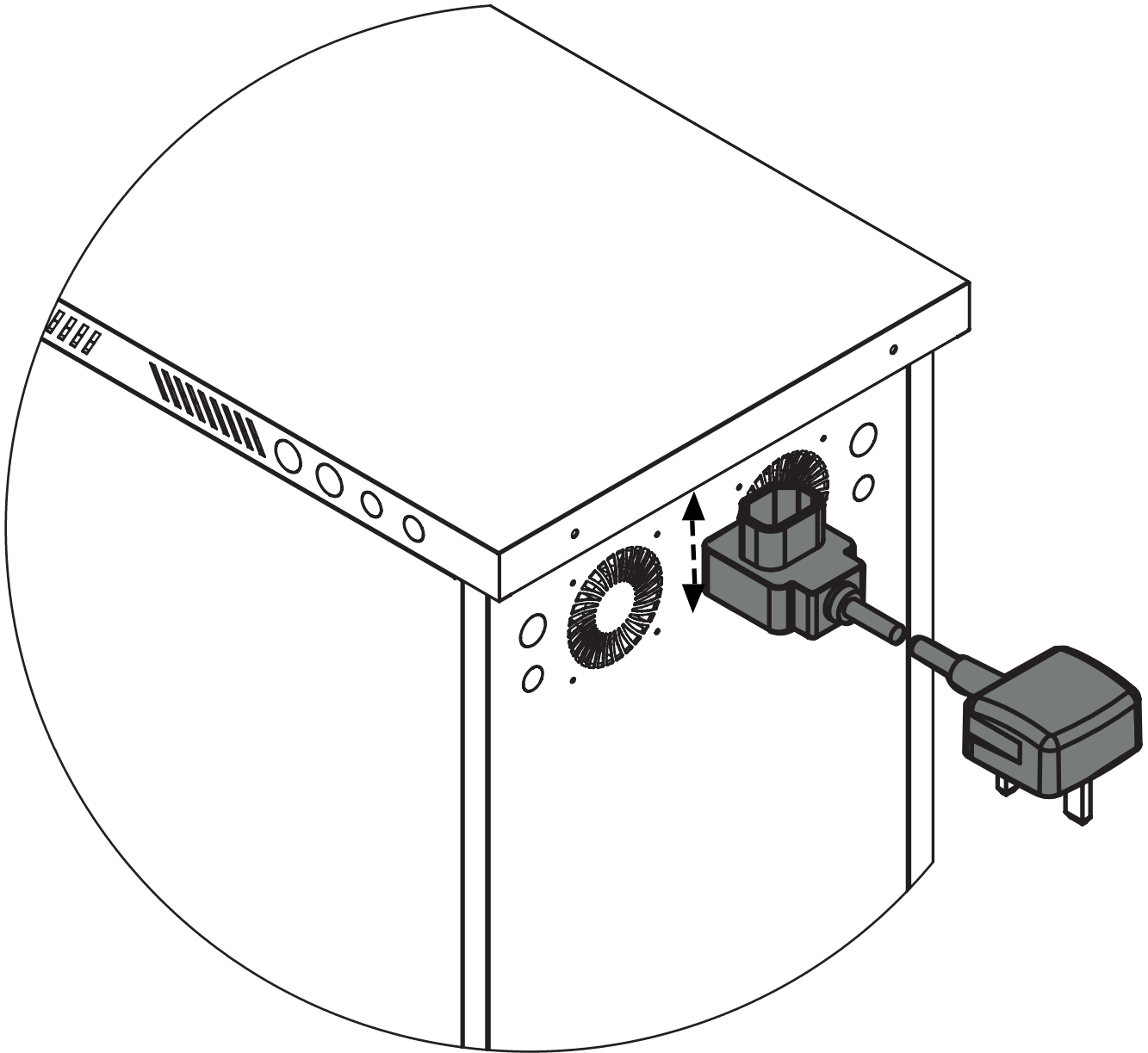

FITTING OF DC SWITCH / COMMON BUSBAR (IF REQUIRED)

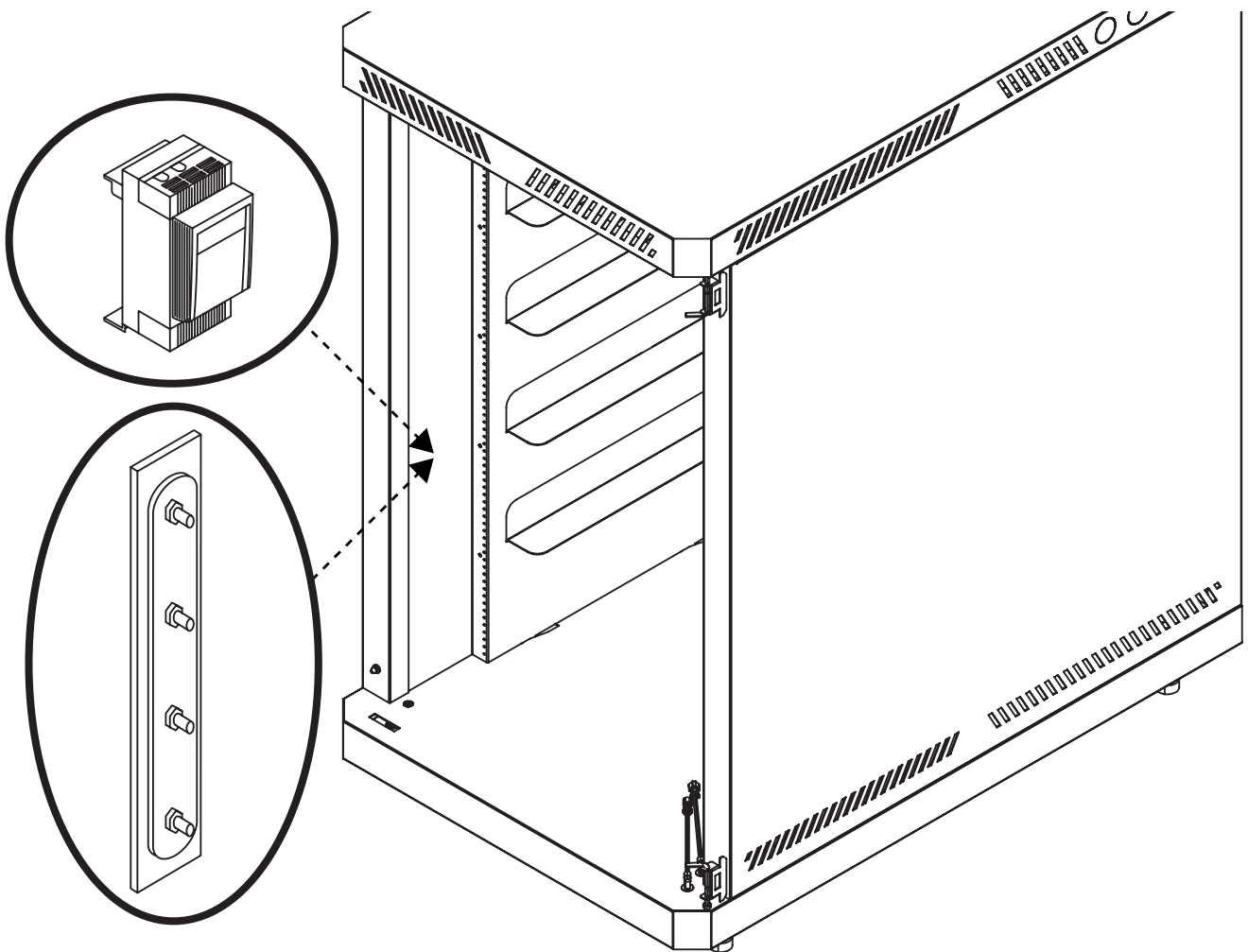

NOTES

NOTES



Contact Us

Call +44 151 832 4300 **Email** sales@sunsynkmobile.com **Website** www.sunsynkmobile.com

Address

- HK** Room 702-704, 7/F Texwood Plaza, 6 How Ming Street, Kwun Tong, Kowloon, Hong Kong.
- UK** Sunsynk UK Ltd, 17 Turnstone Business Park, Mulberry Avenue, Widnes, Cheshire, WA8 0WN.
- SA** Globaltech Sunsynk South Africa (Pty) Ltd, Unit 2 Highview Boulevard, Ferndale 2194.
- NL** Sunsynk NL BV, Henri Wijnmalenweg 8, 5657 EP Eindhoven, Netherlands.